

Unit :mm

Size dox I-i	L	L1	L2	L3	S	Part number
8X2.5-3	33	8	11	24	M4	LL0802.5F-0
12X4-3	33	8	11	33	M6X1	LL1204F-0
12X5-3	30	10	13	33	M6X1	LL1205F-0
12X10-2	25	10	13	33	M6X1	LL1210F-0
16X4-3	38	10	13	39	M6X1	LL1604F-0
16X5-3	42	10	13	39	M6X1	LL1605F-0
16X10-3	45	10	13	39	M6X1	LL1610F-0
16X16-2	32	10	13	39	M6X1	LL1616F-0
20X4-3	38	10	13	47	M6X1	LL2004F-0
20X5-3	42	10	13	47	M6X1	LL2005F-0
20X10-3	54	10	13	47	M6X1	LL2010F-0
20X20-2	40	12	15	51	M6X1	LL2020F-0
25X4-3	38	12	15	52	M6X1	LL2504F-0
25X5-3	50	12	15	52	M6X1	LL2505F-0
25X10-4	76	12	15	52	M6X1	LL2510F-0
25X25-2	47	12	15	61	M6X1	LL2525F-0
32X5-4	55	12	15	66	M6X1	LL3205F-0
32X10-3	78	14	17	66	M6X1	LL3210F-0
32X20-2	90	14	17	69	M6X1	LL3220F-0
32X32-2	58	14	17	75	M6X1	LL3232F-0
40X5-5	55	14	17	71	M8X1	LL4005F-0
40X10-3	82	14	17	79	M8X1	LL4010F-0
40X20-3	69	14	17	79	M8X1	LL4020F-0
40X40-2	69	18	21	87	M8X1	LL4040F-0
50X5-5	52	18	21	87	M8X1	LL5005F-0
50X10-4	91	18	21	96	M8X1	LL5010F-0
50X12-5	90	18	21	96	M8X1	LL5012F-0
50X20-3	91	22	25	106	M8X1	LL5020F-0
50X40-2	71	22	25	106	M8X1	LL5040F-0
63X10-4	104	22	25	113	M8X1	LL6310F-0
63X20-3	96	22	25	113	M8X1	LL6320F-0
80X10-5	111	22	25	126	M8X1	LL8010F-0
80X20-4	160	22	25	146	M8X1	LL8020F-0

## Single nut with flange type F

(double flat with six holes)

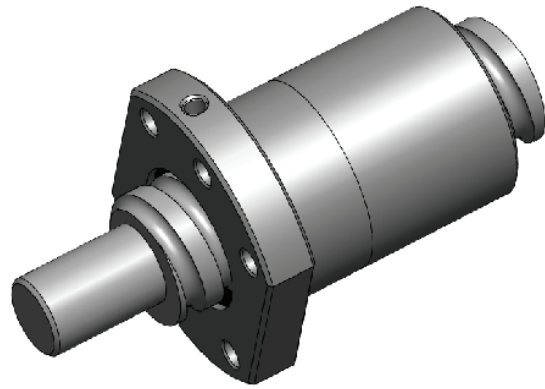

$d_0$ : Nominal diameter

$l$ : Lead

$i$ : Number of track turns

Size $d_0 \times l - i$	dyn. load $C_a$ (KN)	stat. load $C_{0a}$ (KN)	D1 g6	D5	D6	D7
8X2.5-3	2.2	2.8	16	30	23	3.4
12X4-3	3.5	4	22	42	32	4.5
12X5-3	3.8	5.8	22	42	32	4.5
12X10-2	2.5	3.6	22	42	32	4.5
16X4-3	4.35	9.2	28	52	38	5.5
16X5-3	7.65	13.2	28	52	38	5.5
16X10-3	9.6	12.3	30	52	38	5.5
16X16-2	6.3	10.1	30	52	38	5.5
20X4-3	6	10.1	33	58	46	5.5
20X5-3	14.3	21.5	36	58	46	5.5
20X10-3	10.5	17.7	36	58	46	5.5
20X20-2	9.1	12.1	38	62	50	5.5
25X4-3	6.1	10.4	38	64	51	6.5
25X5-3	15.9	27.2	40	64	51	6.5
25X10-4	11.2	24.2	42	64	51	6.5
25X25-2	10.1	15.1	42	74	60	6.5
32X5-4	21.6	40	48	80	65	6.5
32X10-3	25.5	46.9	50	82	65	9
32X20-2	13.5	21.8	55	85	68	9
32X32-2	13.4	22	50	92	74	9
40X5-5	29.1	64.1	56	90	70	9
40X10-3	33.8	69.3	63	98	78	9
40X20-3	37.9	62.8	68	98	78	9
40X40-2	25.5	40.3	68	110	86	11
50X5-5	31.5	80.3	68	110	86	9
50X10-4	43.4	90.7	75	118	95	11
50X12-5	53.1	110.9	75	118	95	11
50X20-3	47.8	87.5	78	128	105	11
50X40-2	32.1	55.8	75	128	105	11
63X10-4	74	178.6	90	138	112	14
63X20-3	53.2	112.1	93	138	112	14
80X10-5	84.4	227.1	105	150	125	14
80X20-4	131.4	267.1	125	165	145	14